

## Dia 1. Vulcan Hector

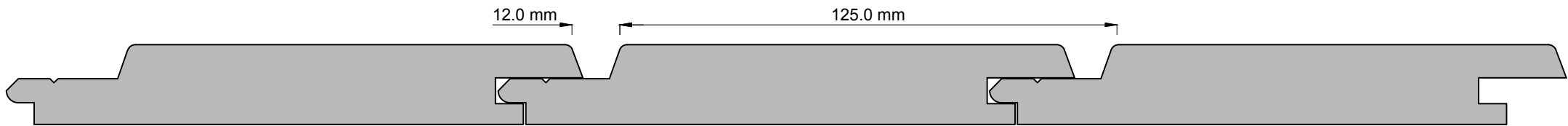

Diagrams not to scale, for illustration purposes only

## Dia 2. Vulcan Hector XS/50

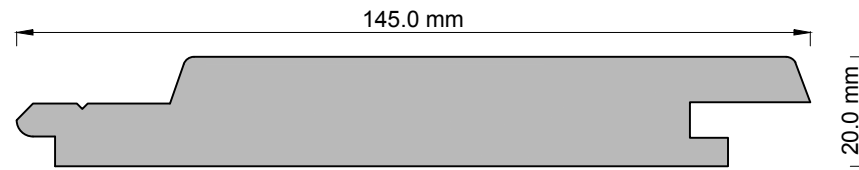
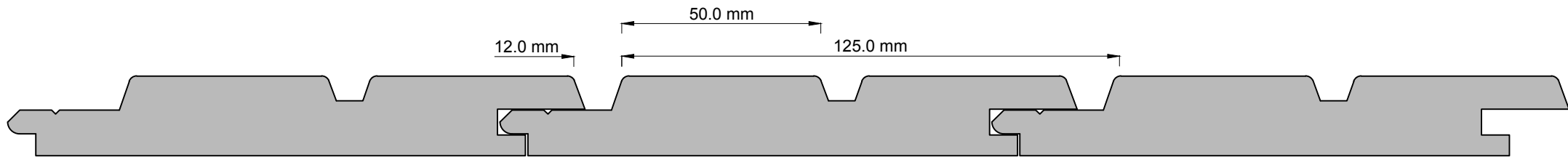
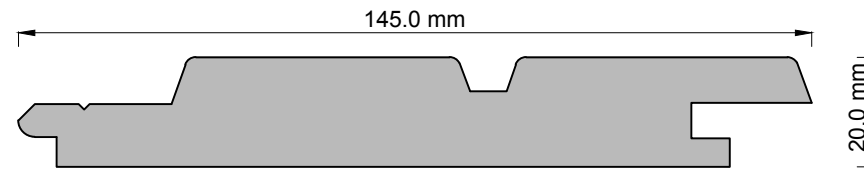

Diagrams not to scale, for illustration purposes only

## Dia 22. Vulcan Hector XS/30

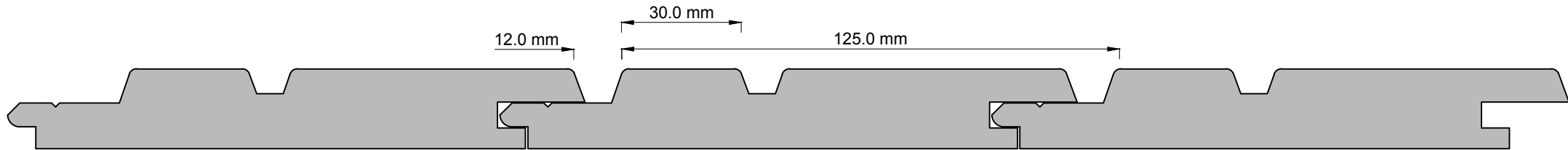
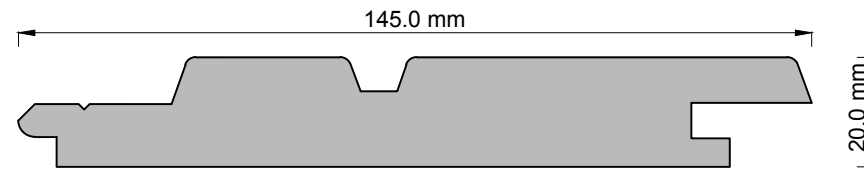

Diagrams not to scale, for illustration purposes only

### Dia 3. Vulcan Hector XL

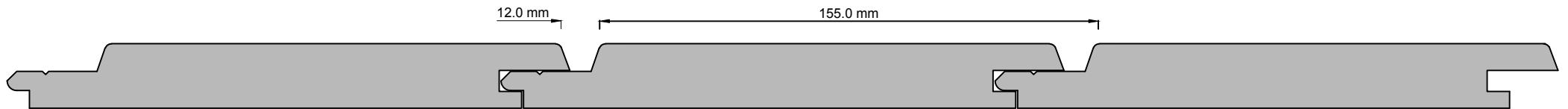
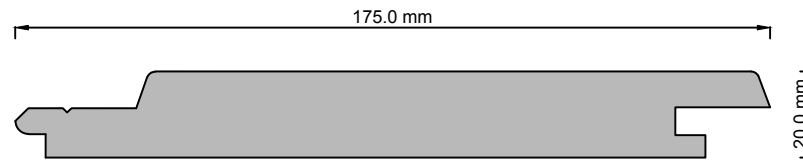

Diagrams not to scale, for illustration purposes only

Dia 4. 54x54 mm External Corner Timber

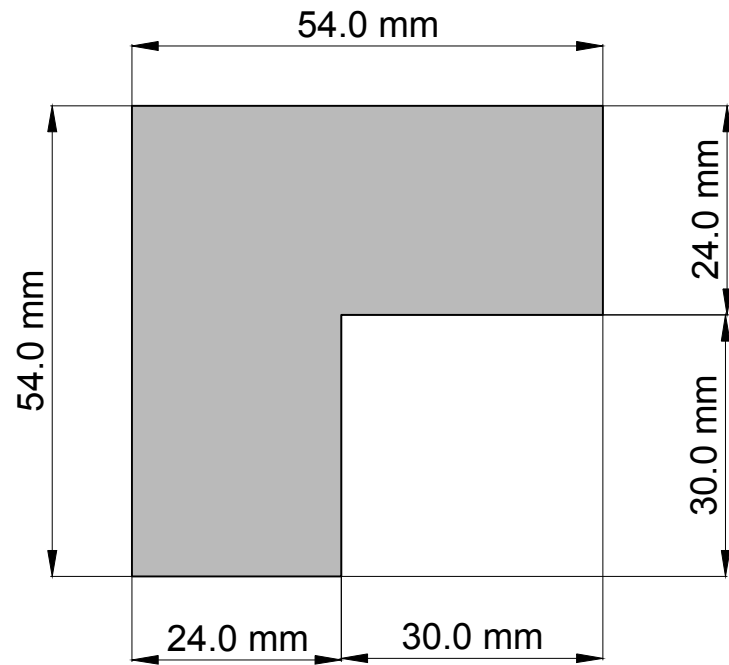

Dia 4a. 42x42 mm External Corner Timber

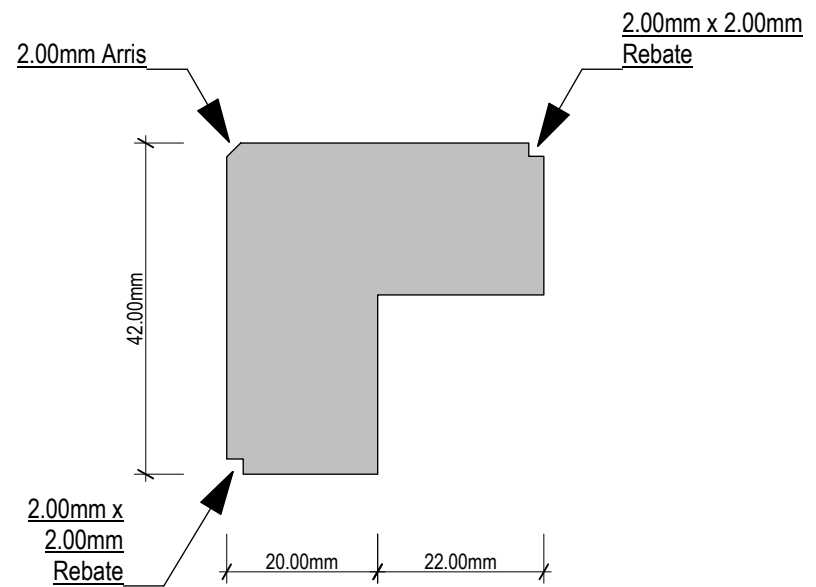

Diagrams not to scale, for illustration purposes only

Dia 5. 24x24 mm Internal Corner Timber

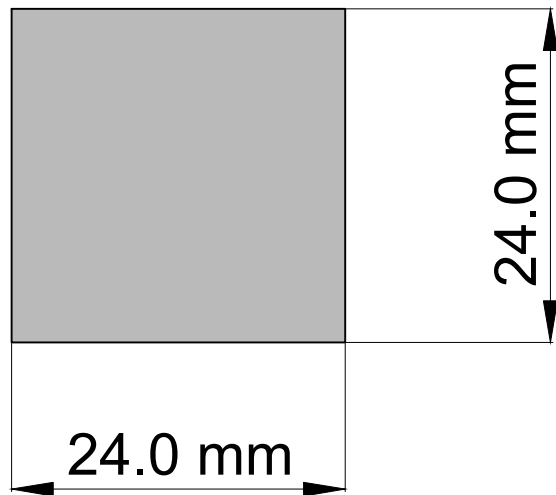

Dia 5a. 22x22 mm Internal Corner Timber

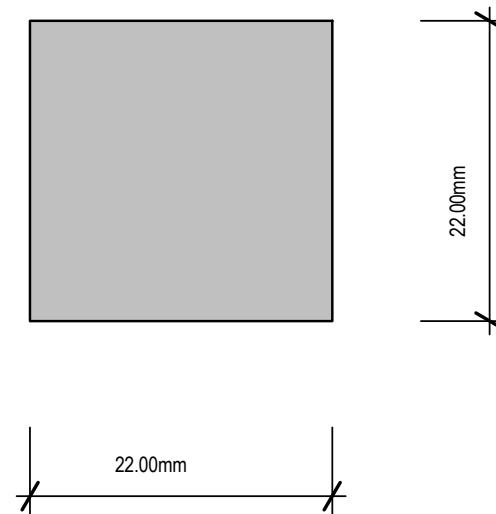

Diagrams not to scale, for illustration purposes only

Dia 6. Austim Aluminum Y Profile for External  
Corner Detail

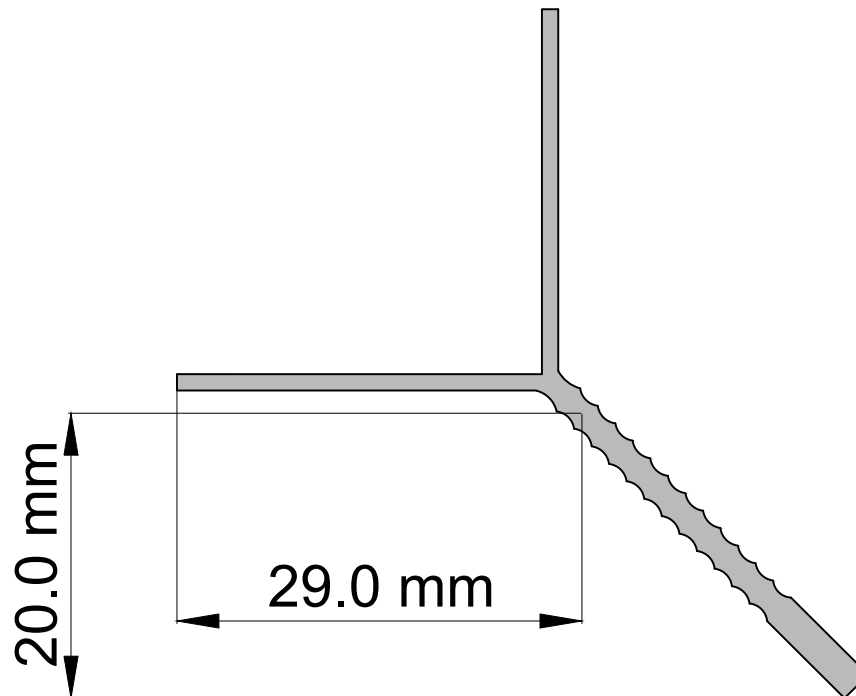

Diagrams not to scale, for illustration purposes only

Dia 7. Austim Aluminum F Profile for Bottom Detail

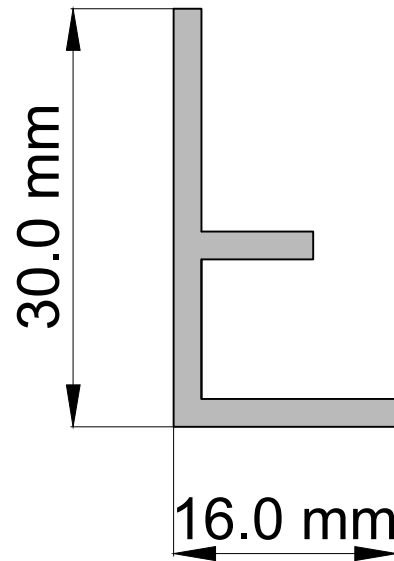

Diagrams not to scale, for illustration purposes only



## Dia 10. Vulcan Victor Lining

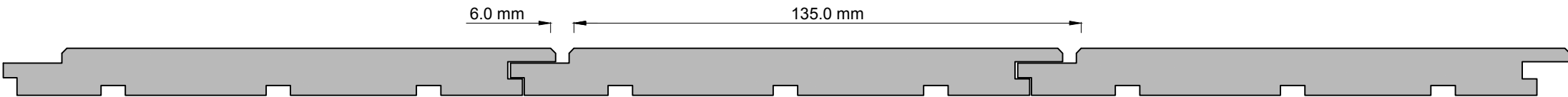
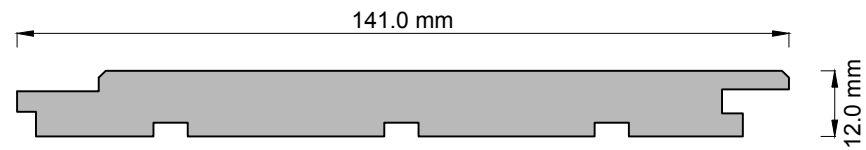

Diagrams not to scale, for illustration purposes only

## Dia 11. Vulcan Tango Lining

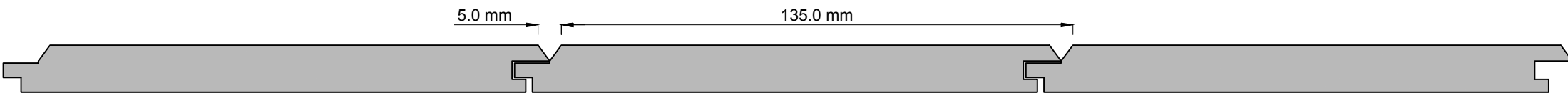
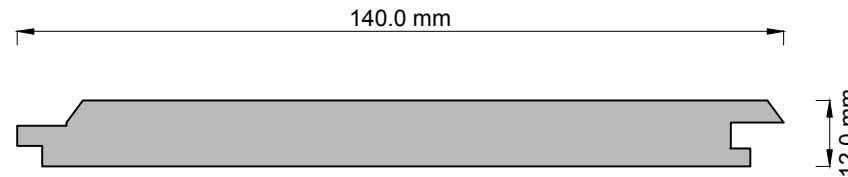

Diagrams not to scale, for illustration purposes only

## Dia 18. Vulcan Echo

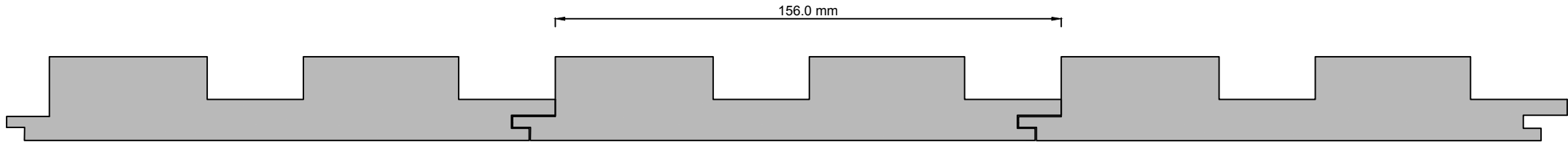
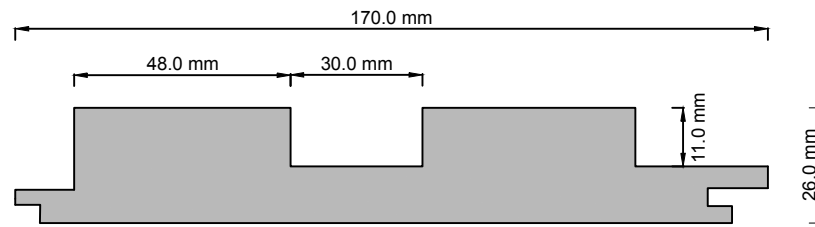

Diagrams not to scale, for illustration purposes only